



www.FGWilson.com

Load Transfer Panel Range

24 Hour Power Protection 365 days a year...

FG Wilson's range of intelligent Load Transfer Panels offer you peace of mind.

The FG Wilson Load Transfer Panel range offers an electronically controlled response to power outages. With flexible, upgradeable options and a high level of functionality FG Wilson transfer panels provide 24-hour automatic control of standby generating sets, 365 days a year.

Why buy an ATI/CTI FG Wilson Load Transfer Panel?

- Automatic and manual operation for increased reliability
- Manual operation possible without opening the panel
- Load Transfer Panel range meets ATS IEC 60947-6-1 standard
- Test operations and sequences are accessible from front panel or remotely
- Fast acting switch, reducing transfer times between set and utility power
- Pre-programmed, allowing the panel to run on installation with the ability to customise if necessary

Illustration of a Load Transfer Panel

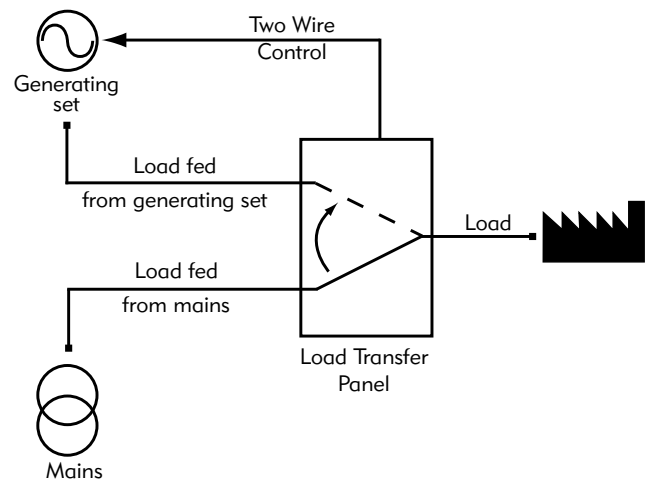

FG Wilson has manufacturing facilities in the following locations:

Northern Ireland • Brazil • China • India • USA

With headquarters in Northern Ireland, FG Wilson operates through a Global Dealer Network.

To contact your local Sales Office please visit the FG Wilson website at www.FGWilson.com

CTI Load Transfer Panel – Ratings 63 – 160 Amps

Key: – Standard Feature – Optional Feature

Programmable Countdown Timers

Set routine times for delay on starts, delay on transfer, delay on re-transfer and run on timer.



Auto/Manual/ Test Mode Status Indication

Allows on/off load tests at routine service checks.



Keypad

For straightforward programming and testing. Password protection is included.



Padlockable

Switch can be padlocked in all three positions for added security and safety. Only possible in manual operation mode.



Manual Handle

Fully integrated handle for manual operation.



Auxiliary Contacts

Auxiliary/volt free contacts for remotely monitoring the switch position.



Control Terminals

Generating set remote start signal and terminals for remotely monitoring the system.



Auxiliary Controls

Auxiliary inputs for automatic control, remote test on load and manual re-transfer.



Terminal shroud

For added protection.



Solid Neutral Kit

Allows the connection of neutral cables from utility power, generating set and load without having the neutral broken by the switch during transfer operations.



LCD Display

Shows detailed status of system at all times for greater awareness and control.



System Status Indicators

Shows status of utility power, generating set and switch at all times.

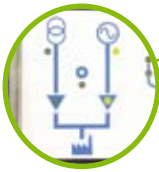

Voltage Sensing Tap

Allows for pole voltage sensing.



Wall Mounting Kit

Panel can be wall mounted for greater flexibility in positioning.



Top and Bottom Cable Entry

Aids ease of installation



Ingress Protection IP54

Protection for the control panel



Load Terminal Extensions

Improving ease of installation



Lightning Protection

Ensuring system safety



ATI Load Transfer Panel – Ratings 250 – 1600 Amps

Key: – Standard Feature – Optional Feature

RS485 Communications Module

Enables access to the system remotely through telephone or PC via modem.



Volt Free Contacts

For power available and generator available.

System Status Indication

Shows status of utility power, generating set and switch at all times.

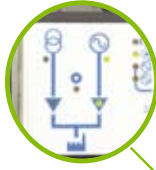

Auto/Manual/Test Mode Status Indication

Allows on/off load tests at routine service checks.

Two Wire Start Signal

Simple two wire connection for automatic control.



LCD Display

Shows detailed status of system at all times for greater awareness and control.

Manual Handle

Fully integrated handle for manual operation.



Power Metering

To measure load current, kW, kVAR, kVA, power factor.

Padlockable

Switch can be padlocked in all three positions for added security and safety.



Keypad

For straightforward programming and testing. Password protection is included.

Solid Neutral

Allows the connection of neutral cables from utility power, generating set and load without having the neutral broken by the switch during transfer operations.



Programmable Countdown Timers

Set routine times for delay on starts, delay on transfer, delay on re-transfer and run on timer.

Wall Mounting Kit

Panel can be wall mounted for greater flexibility in positioning (ATI 250 and 400).



Lightning Protection

Ensures the safety of system during lightning storms (includes volt free contacts for utility power and generating set).

Bottom Gland Plate

Removable gland plate providing increased accessibility with a sizeable area for utility power and generating set cables to be connected.



Auxiliary Contacts

Auxiliary / volt free contacts for remotely monitoring system; switch position, padlock and automatic or manual operation.

Installation

Typical installation set up

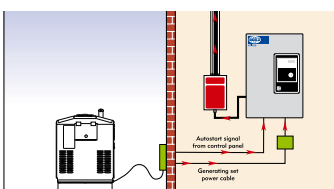

Wall Mounting Panels

Wall mount with ease – includes fittings



Ingress Protection IP54

Protection for the control panel



Top Cable Entry

Aids eased installation



CTI/ATI Standard and Optional Features

	CTI	ATI
Motorised Mechanically Held Switch	●	●
Facility for manual changeover		
Status Indication	●	●
Utility power available		
Utility power on load		
Generator available / Generator on load		
Utility power and generator off load		
Manual mode / Automatic mode		
Test on load / Test off load		
Manual re-transfer for enabled / required		
Power / Error indication (LED)		
Facia	●	●
Universal symbols to allow for multiple languages		
Liquid Crystal Display (LCD)	●	●
Utility power L1-2, L1-3, L2-3 voltage		
Utility power L1-N, L2-N, L3-N voltage		
Generating set L1-N, L2-N, L3-N voltage		
Generating set L1-2, L1-3, L2-3 voltage		
Utility power frequency / Generating set frequency		
Number of times switch transfers from mains to generating set		
Timer settings		
Standards	●	●
Complete enclosure meets standard IEC 60947-6-1		
Switch meets standard AC31B		
Controls	●	●
Under / over frequency failure		
Under / over frequency restoration		
Manual / auto re-transfer		
Mode select push button		
Under / over volts failure		
Under / over volts restoration		
Delay on start timer		
Delay on transfer		
Delay on re-transfer		
Dead band timer		
Run on timer		
Auto / manual control keyswitch		
Lamp test pushbutton		
Padlock facility		
Selection between contactor or switch mode	●	

	CTI	ATI
Cable entry		
Top	●	■
Bottom	●	●
Load Terminal Extensions	■	
Improving ease of installation		
Auxiliary Contacts	■	■
For switch position (padlocking & auto/manual - ATI only)		
Lightning Protection	■	■
Ensuring the safety of system during lightning storms		
Ingress Protection IP54	■	■
Protection for the control module		
Power Metering		■
To measure load current, kW, kVA, kVA, Power factor		
Volt Free Contacts	●	■
For utility power available & generator available		
Communications Module		■
Plug in module that uses Jbus/modbus protocol to allow remote communication of the change over system		
Voltage Sensing Tap	■	
Allowing for pole voltage sensing		
Solid Neutral Kit	■	■
To connect neutral cables from the mains, generating set and load		
Terminal Shroud	■	
For added protection		

Key:

- – standard feature
- – optional feature

Panel Weights and Dimensions

Model	Rating	A mm (in)	B mm (in)	C mm (in)	Weight kg (lb)
CTI 63	63 A	600 (23.6)	400 (15.7)	200 (7.9)	19 (41.8)
CTI 100	100 A	600 (23.6)	400 (15.7)	200 (7.9)	19 (41.8)
CTI 125	125 A	600 (23.6)	400 (15.7)	200 (7.9)	19 (41.8)
CTI 160	160 A	600 (23.6)	400 (15.7)	200 (7.9)	19 (41.8)

Model	Rating	A mm (in)	B mm (in)	C mm (in)	Weight kg (lb)
ATI 250	250 A	900 (35.4)	600 (23.6)	323 (12.7)	39 (86.0)
ATI 400	400 A	900 (35.4)	600 (23.6)	323 (12.7)	44 (97.0)
ATI 630*	630 A	1100 (43.3)†	600 (23.6)	398 (15.7)	66 (145.5)
ATI 800*	800 A	1375 (54.1)	775 (30.5)	600 (23.6)	125 (275.6)
ATI 1000*	1000 A	1375 (54.1)	775 (30.5)	600 (23.6)	130 (286.6)
ATI 1250*	1250 A	1800 (70.8)	1005 (39.6)	775 (30.5)	230 (507.1)
ATI 1600*	1600 A	1800 (70.8)	1005 (39.6)	775 (30.5)	330 (727.7)

*Floor standing. †Dimension A for the top cable entry model will change to 1350 mm (53.1 in)

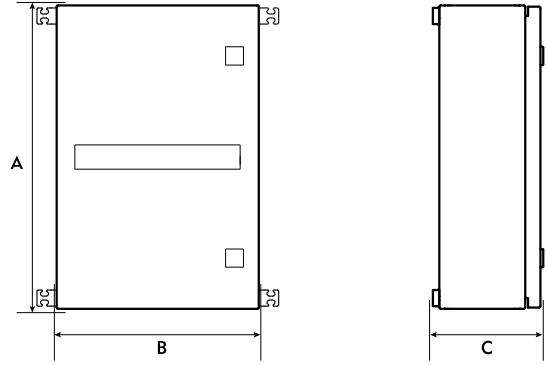

CTI wall mounted

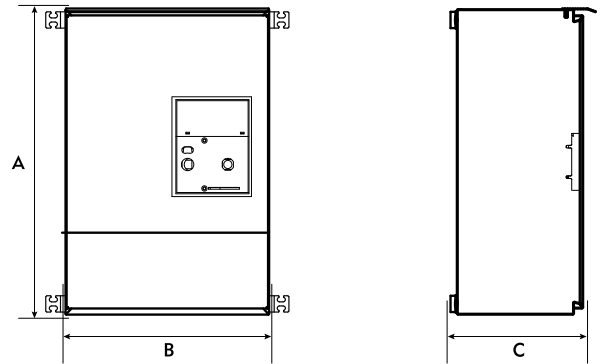

ATI wall mounted

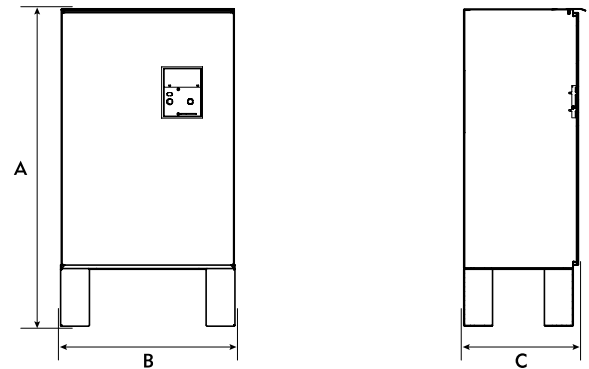

Floor standing (ATI only)

From your local dealer

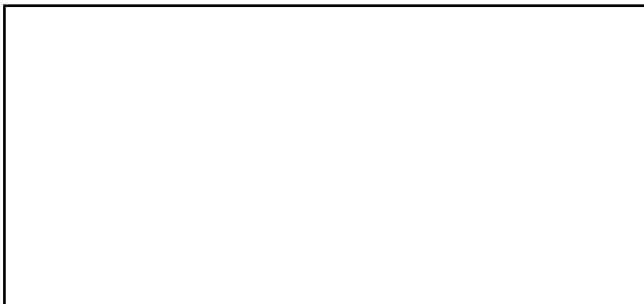

FG Wilson has manufacturing facilities in the following locations:

Northern Ireland • Brazil • China • India • USA

With headquarters in Northern Ireland, FG Wilson operates through a Global Dealer Network.

To contact your local Sales Office please visit the FG Wilson website at www.FGWilson.com

In line with our policy of continuous product development, we reserve the right to change specification without notice.

Load Transfer Panel Range/0111/GB