

The FG Wilson fully weatherproof sound attenuated (SA) enclosures reduce sound levels to comply with the stage 2 levels of the European Community Directive 2000/14/EC which became effective 3 January 2006.

These enclosures incorporate internally mounted exhaust silencers and are of extremely rugged construction in order to withstand the rough handling common on many construction sites. The panel is viewed through a hinged perspex window.

Highly Corrosion Resistant Construction

- ▶ Stainless steel locks
- ▶ Black zinc die cast hinges on gullwing doors tested and proven to withstand extremely corrosive conditions
- ▶ Zinc plated or stainless steel fasteners and hinges
- ▶ Body made from steel components pre-treated with zinc phosphate prior to polyester powder coating

Excellent Access for Maintenance

- ▶ Top hung gullwing doors
- ▶ Hinged and lockable end panels
- ▶ Radiator fill access through radiator end panel
- ▶ Lube oil drain piped to exterior of the canopy

Security and Safety

- ▶ Perspex control panel viewing window in a lockable access door
- ▶ Emergency stop button mounted on canopy exterior
- ▶ End panels secured by internal latches with safety retainer
- ▶ Cooling fan and battery charging alternator fully guarded
- ▶ Fuel fill and battery can only be reached via lockable access doors
- ▶ Exhaust silencing system enclosed for operator safety

Transportability

- ▶ Tested and certified single point lifting facility

Optional Features

- ▶ Lockable vandal proof control panel cover in place of window.



10 - 22 kVA
Range



Modular
Acoustic Enclosure



Sound Pressure Levels (dba)													
		50Hz at 1500 RPM						60Hz at 1800 RPM					
		15m (50ft)		7m (23ft)		1m (3ft)		15m (50ft)		7m (23ft)		1m (3ft)	
Generating Set Model	LWA	75% Load	100% Load	75% Load	100% Load	75% Load	100% Load	75% Load	100% Load	75% Load	100% Load	75% Load	100% Load
3 Phase Models													
P12.5P2	91	61.1	62.5	67.1	68.5	76.6	77.9	59.7	59.8	65.8	65.8	77.2	77.1
P13.5E2	91	61.5	63.0	67.5	69.0	77.0	78.3	59.7	59.8	65.8	65.8	77.2	77.1
P16.5P2	91	58.2	59.5	64.2	65.5	73.9	75.3	59.2	60.5	65.2	66.5	75.4	76.7
P18E2	91	58.5	60.1	64.5	66.1	74.2	75.9	59.6	61.0	65.6	67.0	75.7	77.3
P20P2	91	59.0	61.0	65.0	67.0	74.7	76.9	59.8	61.4	65.8	67.4	76.0	77.7
P22E2	91	59.5	62.0	65.5	68.0	75.3	78.1	60.3	62.3	66.3	68.3	76.5	78.7
Single Phase Models													
P10P2S	91	60.3	61.4	66.3	67.4	75.8	76.9	59.7	59.8	65.8	65.8	77.2	77.1
P11E2S	91	60.6	61.8	66.6	67.8	76.1	77.3	59.7	59.8	65.8	65.8	77.2	77.1
P13P2S	91	57.7	58.4	63.7	64.4	73.3	74.1	58.8	59.6	64.8	65.6	75.0	75.8
P14E2S	91	57.8	58.6	63.8	64.6	73.5	74.4	58.9	60.0	64.9	66.0	75.1	76.1
P15P2S	91	58.0	59.0	64.0	65.0	73.6	74.7	59.1	60.3	65.1	66.3	75.3	76.5
P16.5E2S	91	58.2	59.5	64.2	65.5	73.9	75.3	59.5	60.8	65.5	66.8	75.6	77.1

Levels in accordance with European Noise Directive (2000/14/EC)

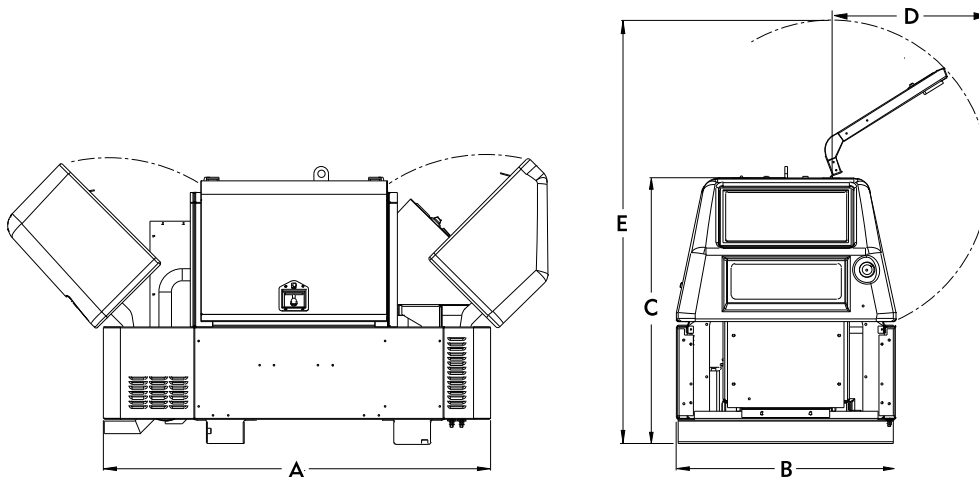

Dimensions and Weights							
Generating Set Model	A: mm (in)	B: mm (in)	C: mm (in)	D: mm (in)	E: mm (in)	Weight: kg (lb)	Fuel Capacity: l (US gal)
3 Phase Models							
P12.5P2/P13.5E2	1593 (62.7)	900 (35.4)	1275 (50.2)	880 (34.6)	1850 (72.8)	580 (1279)	45 (12)
P16.5P2/P18E2	1593 (62.7)	900 (35.4)	1255 (49.4)	880 (34.6)	1850 (72.8)	641 (1413)	45 (12)
P20P2/P22E2	1593 (62.7)	900 (35.4)	1255 (49.4)	880 (34.6)	1850 (72.8)	654 (1442)	45 (12)
Single Phase Models							
P10P2S/P11E2S	1593 (62.7)	900 (35.4)	1275 (50.2)	880 (34.6)	1850 (72.8)	580 (1279)	45 (12)
P13P2S/P14E2S	1593 (62.7)	900 (35.4)	1255 (49.4)	880 (34.6)	1850 (72.8)	641 (1413)	45 (12)
P15P2S/P16.5E2S	1593 (62.7)	900 (35.4)	1255 (49.4)	880 (34.6)	1850 (72.8)	654 (1442)	45 (12)

Note: Net Weight with lube oil, no coolant, no fuel; *Clearance required both sides.



FG Wilson has manufacturing facilities in the following locations:

Northern Ireland • Brazil • China • India • USA

With headquarters in Northern Ireland, FG Wilson operates through a Global Dealer Network. To contact your local Sales Office please visit the FG Wilson website at www.FGWilson.com

